

POST MID-TERM EXAMINATION
CLASS XII (2024-25)
PHYSICS (042)
SET B2

Time allowed: 3 hours.

Max. Marks: 70

General Instructions:

1. This paper has 11 pages. There are 33 questions in all. All questions are compulsory.
2. This question paper has five sections: Section A, Section B, Section C, Section D and Section E.
3. All the sections are compulsory.
4. **Section A** contains sixteen questions, twelve MCQ, and four Assertion Reasoning based of 1 mark each, **Section B** contains five questions of two marks each, **Section C** contains seven questions of three marks each, **Section D** contains two case study-based questions (CBQ) of four marks each and **Section E** contains three long answer questions of five marks each.
5. There is no overall choice. However, an internal choice has been provided in one question in Section B, one question in Section C, one question in each CBQ in Section D, and all three questions in Section E. You have to attempt only one of the choices in such questions.
6. Use of calculators is not allowed.
7. You may use the following values of physical constants wherever necessary
 - i. $c = 3 \times 10^8$ m/s
 - ii. $m_e = 9.1 \times 10^{-31}$ kg
 - iii. $e = 1.6 \times 10^{-19}$ C
 - iv. $\mu_0 = 4\pi \times 10^{-7}$ TmA⁻¹
 - v. $h = 6.63 \times 10^{-34}$ Js
 - vi. $\epsilon_0 = 8.854 \times 10^{-12}$ C²N⁻¹m⁻²
 - vii. Avogadro's number = 6.023×10^{23} per gram mole

SECTION A

1. The source of electromagnetic waves can be an electric charge, when
 - (a) moving with a constant velocity
 - (b) falling in an electric field
 - (c) moving in a circular orbit
 - (d) both (b) and (c).
2. The self-inductance of the motor of an electric fan is 10 H. In order to impart maximum power at 50 Hz, it should be connected to a capacitance of
 - (a) 1 μ F
 - (b) 2 μ F
 - (c) 4 μ F
 - (d) 8 μ F
3. If Young's double slit experiment for interference of light is performed in water, which of the following is correct?

- (a) fringe width will decrease.
 - (b) fringe width will increase.
 - (c) there will be no fringe.
 - (d) fringe width will remain unchanged.
4. The wavelength of light in the visible region is about 390 nm for violet colour and about 760 nm for red colour. The energy of the photon in eV at the violet end is
- (a) 2.32
 - (b) 3.19
 - (c) 1.42
 - (d) 4.13
5. The distance of closest approach of an alpha particle is d when it is projected with a speed V towards a nucleus. Another alpha particle is projected with higher energy such that the new distance of the closest approach is $d/2$. What is the speed of projection of the alpha particle in this case?
- (a) $V/2$
 - (b) $\sqrt{2} V$
 - (c) $2 V$
 - (d) $4 V$
6. In an ammeter, 10% of the main current passes through the galvanometer. If the resistance of the galvanometer is 'G', then the shunt resistance, in Ohm, is-
- (a) $9G$
 - (b) $G/9$
 - (c) $90G$
 - (d) $G/90$
7. If a magnetic material has magnetic susceptibility (χ) = -1, then the relative magnetic permeability (μ_r) and type of magnetic material is
- (a) 0, diamagnetic
 - (b) 2, ferromagnetic
 - (c) 1, paramagnetic
 - (d) -1, diamagnetic.
8. A conducting wire connects two charged conducting spheres of radii r_1 and r_2 such that they attain equilibrium with respect to each other. The distance of separation between the two spheres is very large as compared to either of their radii.

The ratio of the magnitudes of the electric fields at the surfaces of the spheres of radii r_1 and r_2 is

- (a) r_1/ r_2
- (b) r_2/ r_1
- (c) r_2^2/ r_1^2
- (d) r_1^2/r_2^2

9. Figure shows the field lines of a positive point charge. The work done by the field in moving a small positive charge from Q to P is

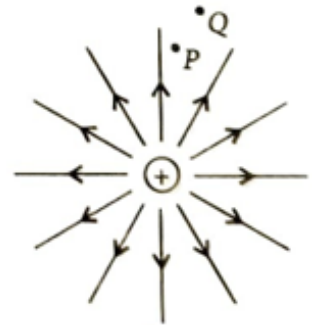

- (a) zero
- (b) positive
- (c) negative
- (d) data insufficient.

10. Drift speed of electrons, when 1.5 A of current flows in a copper wire of cross-sectional area 5 mm^2 is v . If the electron density of copper is $9 \times 10^{28}/\text{m}^3$ the value of v in mm/s is close to (Take charge of electron to be $= 1.6 \times 10^{-19} \text{ C}$)

- (a) 3
- (b) 0.2
- (c) 2
- (d) 0.02

11. Correct match of column I with column II is

C-I (waves)	C-II (Production)
(1) Infra-red	P . Rapid vibration of electrons in aerials
(2) Radio	Q . Electrons in atoms emit light when they move from higher to lower energy level.
(3) Light	R . Klystron valve
(4) Microwave	S . Vibration of atoms and molecules

- (a) 1-P, 2-R, 3-S, 4-Q
- (b) 1-S, 2-P, 3-Q, 4-R
- (c) 1-Q, 2-P, 3-S, 4-R
- (d) 1-S, 2-R, 3-P, 4-Q

12. A power transmission line feeds input power at 2300 V to a step-down transformer with its primary windings having 4000 turns. The output power is delivered at 230 V by the

transformer. If the current in the primary of the transformer is 5 A and its efficiency is 90%, the output current would be

- (a) 25 A
- (b) 50 A
- (c) 45 A
- (d) 35 A

For Questions 13 to 16, two statements are given -one labeled Assertion (A) and the other labeled Reason (R). Select the correct answer to these questions from the options given below.

- (a) If both Assertion and Reason are true and Reason is the correct explanation of Assertion.
- (b) If both Assertion and Reason are true but Reason is not the correct explanation of Assertion.
- (c) If Assertion is true but Reason is false.
- (d) If both Assertion and Reason are false.

13. Assertion (A): The mass of a nucleus is always less than the sum of the masses of independent nucleons constituting it.

Reason (R): The whole mass of the atom is concentrated in the nucleus.

14. Assertion (A): On increasing the current sensitivity of a galvanometer by increasing the number of turns does not necessarily increase its voltage sensitivity.

Reason(R) : The resistance of the coil of the galvanometer increases on increasing the number of turns.

15. Assertion (A): Infrared radiation plays an important role in maintaining the average temperature of earth.

Reason (R): Infrared radiations are sometimes referred to as heat waves.

16. Assertion (A): The work function of a given material increases with an increase in the frequency of the incident radiation.

Reason (R): As per Einstein's photoelectric equation $h\nu = \phi + KE$, work function ϕ is directly proportional to the frequency ν of the incident radiation.

SECTION B

17. A compound microscope consists of an objective lens of focal length 2.0 cm and an eyepiece of focal length 6.25 cm separated by a distance of 15 cm. How far from the objective should an object be placed in order to obtain the final image at the least distance of distinct vision (25 cm)?

18. State Huygen's principle. Consider a plane wavefront incident on a thin prism. Draw a proper diagram to show how the incident wavefront traverses through the prism, giving the shape of the emergent wavefront.

19. Explain the following giving reasons:

(a) Food items to be heated in microwave must contain water.

(b) Welders wear face mask with glasses during welding.

20. A closely wound solenoid of 1000 turns and area of cross-section 2 cm^2 carries a current of 2 A. It is placed with its horizontal axis at 30° with the direction of a uniform magnetic field of 0.16 T, as shown in the figure.

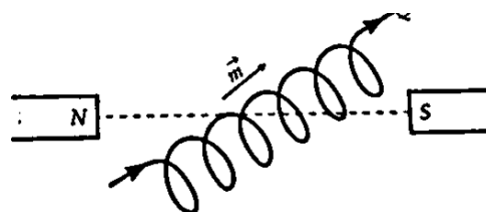

(i) What is the torque experienced by the solenoid due to the field?

(ii) If the solenoid achieves a stable equilibrium, calculate the change in potential energy of the system.

21. Calculate binding energy per nucleon of ${}_{26}\text{Fe}^{56}$.

Given: $m({}_{26}\text{Fe}^{56}) = 55.934932 \text{ amu}$

$m(\text{neutron}) = 1.008665 \text{ amu}$

$m(\text{proton}) = 1.007825 \text{ amu}$.

OR

21. The total energy of an electron in the first excited state of the H-atom is -3.4 eV. What are the values of the potential and kinetic energies of the electron in this state? Which of the answers would change if the choice of zero of potential energy is changed?

SECTION C

22. (i) Define mutual inductance. State its S.I. unit.

(ii) Derive an expression for the mutual inductance of a system of two long coaxial solenoids of same length l , having turns N_1 and N_2 and of radii r_1 and r_2 ($>r_1$).

23. A square metal wire loop of side 10 cm and resistance 1Ω is moved with a constant velocity v_0 in a uniform magnetic field of induction $B = 2 \text{ Wbm}^{-2}$ as shown in the figure. The magnetic lines are perpendicular to the plane of the loop (directed into the paper).

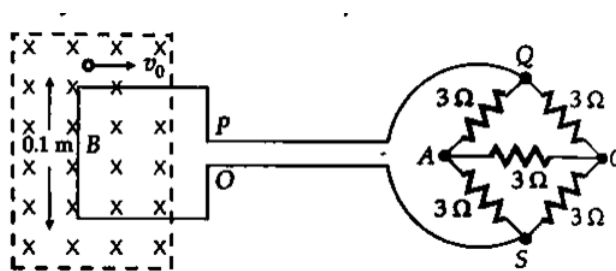

The loop is connected to a network of resistors each of value 3Ω . The resistances of the loop wires OS and PQ are negligible. What should be the speed of the loop to have a steady current of 1 mA in the loop? Give the direction of the current in the loop.

24. A current I enters a uniform circular loop of radius R at point M and flows out at N as shown in the figure. Obtain the net magnetic field at the centre O of the loop.

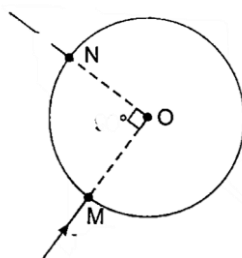

25. The work function for the following metals is given:

Which of these metals will not give photoelectric emission for a radiation of wavelength 3300 \AA from a He-Cd laser placed 1 m away from the photocell? What happens if the laser is brought nearer and placed 50 cm away?

Na	2.75 eV
K	2.30 eV
Mo	4.17 eV
Ni	5.15 eV

OR

25. Define the term "cut-off frequency" in photoelectric emission. The threshold frequency of a metal is f . When the light of frequency $2f$ is incident on the metal plate, the maximum velocity of the photoelectron is v_1 . When the frequency of the incident radiation is increased to $5f$, the maximum velocity of photoelectrons is v_2 . Find the ratio $v_1 : v_2$.
26. Draw the circuit diagram of a device that utilizes the unilateral action of a pn junction diode to convert ac to a half wave dc. Explain its working.
27. Sixty four drops of radius 0.02 m and each carrying a charge of $5 \mu\text{C}$ are combined to form a bigger drop. Find how the surface charge density will change if no charge is lost.
28. In a hydrogen atom, an electron undergoes a transition from 2^{nd} excited state to the first excited state and then to the ground state. Identify the spectral series to which these transitions belong. Find out the ratio of the wavelengths of the emitted radiations in the two cases.

SECTION D (Case Study Based Questions)

29. Read the following paragraph and answer the questions that follow.

An astronomical telescope is an optical instrument that is used for observing distinct images of heavenly bodies like stars, planets, etc. It consists of two lenses. In the normal adjustment of a telescope, the final image is formed at infinity. The magnifying power of an astronomical telescope in normal adjustment is defined as the ratio of the angle subtended at the eye by the angle subtended at the eye by the final image to the angle subtended at the eye, by the object directly, when the final image and the object both lie at infinite distance from the eye. It is given by, $m = f_o/f_e$. To increase the magnifying power of an astronomical telescope in normal adjustment, the focal length of the objective lens should be large and the focal length of the eye lens should be small.

- (i) An astronomical telescope of magnifying power 7 consists of two thin lenses 40 cm apart, in normal adjustment. The focal lengths of the lenses are
- (a) 5 cm, 35 cm
 - (b) 7 cm, 35 cm
 - (c) 17 cm, 35 cm
 - (d) 5 cm, 30 cm
- (ii) The Cassegrain telescope is advantageous because:
- (a) It has spherical aberrations.
 - (b) It has chromatic aberrations.
 - (c) It does not have spherical aberrations.
 - (d) It uses lenses instead of mirrors.
- (iii) In an astronomical telescope, compared to an eyepiece, the objective lens has
- (a) negative focal length
 - (b) small focal length
 - (c) zero focal length
 - (d) large focal length.

OR

- (iii) For the large magnifying power of an astronomical telescope
- (a) $f_o \ll f_e$

- (b) $f_o=f_e$
- (c) $f_o \gg f_e$
- (d) none of these

(iv) An astronomical telescope uses lenses of power 10 D and 1 D. What is its magnifying power in normal adjustment?

- (a) 1
- (b) 10
- (c) 0.1
- (d) 11

30. Read the following paragraph and answer the questions that follow.

A semiconductor diode is a pn junction with metallic contacts provided at the ends for the application of an external voltage. It is a two-terminal device. When an external voltage is applied across a semiconductor diode such that the p-side is connected to the positive terminal of the battery and the n-side to the negative terminal, it is said to be forward-biased. When an external voltage is applied across the diode such that the n-side is positive and the p-side is negative, it is said to be reverse-biased. An ideal diode is one whose resistance in forward biasing is zero and the resistance is infinite in reverse biasing. When the diode is forward biased, it is found that beyond forward voltage called knee voltage, the conductivity is very high. When the biasing voltage is more than the knee voltage the potential barrier is overcome and the current increases rapidly with an increase in forward voltage. When the diode is reverse biased, the reverse bias voltage produces a very small current of about a few microamperes which almost remains constant with bias. This small current is a reverse saturation current.

(i) In the given figure, a diode D is connected to an external resistance $R = 100 \Omega$ and an emf of 3.5 V. If the barrier potential developed across the diode is 0.5 V, the current in the circuit will be:

- (a) 40 mA
- (b) 20 mA
- (c) 35 mA
- (d) 30 mA

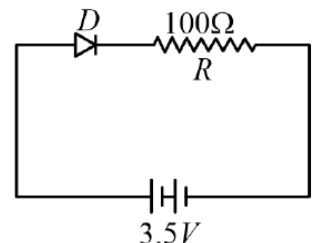

(ii) In which of the following figures, the pn diode is reverse biased?

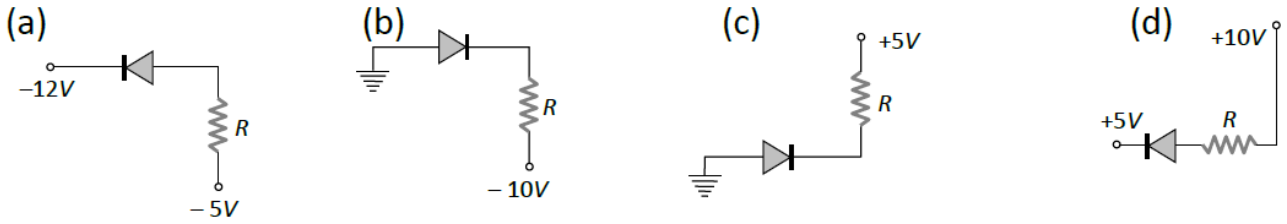

OR

- (ii) In the depletion layer of an unbiased p-n junction diode, there are
- Holes
 - Mobile ions
 - Electrons
 - Immobile ions
- (iii) The V-I characteristic of a diode is shown in the figure. The dynamic resistance of the diode at $I = 15 \text{ mA}$ is nearly-

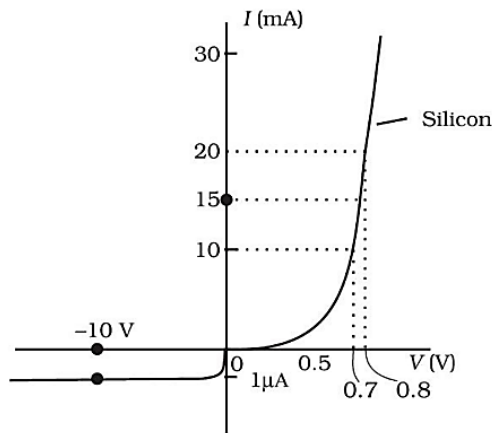

- 100
 - 10^6
 - 10
 - 10^{-6}
- (iv) In the following diagram consisting of two diodes D_1 and D_2 , and two bulbs B_1 and B_2 , which of the statements is true?

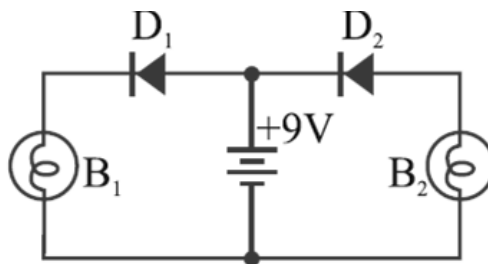

- Diode D_1 is forward biased and bulb B_1 will glow.
- Diode D_2 is reverse biased and bulb B_2 will glow.
- Diode D_1 is reverse biased and bulb B_2 will glow.
- Diode D_2 is forward biased and bulb B_1 will glow.

SECTION E

31. (a) Explain Young's double slit experiment of interference of light waves and calculate the path difference between the interfering waves. Give the conditions for maxima and minima.
- (b) In a Young's double slit experiment, the path difference at a certain point on the screen between two interfering waves is $\frac{1}{3}$ rd of the wavelength. Find the ratio of intensity at this point to that at the centre of a bright fringe.

OR

31. (a) Derive Lensmaker's formula for a thin convex lens of a given refractive index.
- (b) Find the position of the image formed by the lens combination given in the figure. All values are in cm.

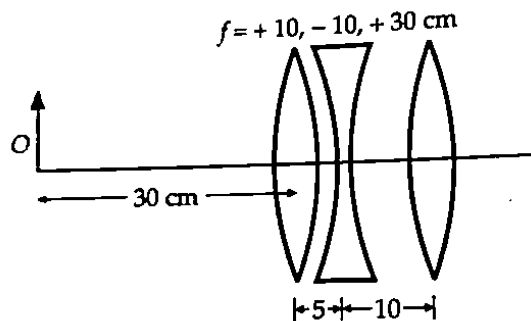

32. (i) The electric potential V as a function of distance x is shown in the given figure. Draw a graph of the electric field strength E as a function of x .

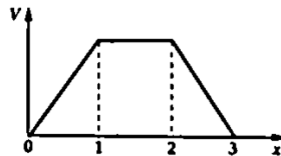

- (ii) Four point charges Q, q, Q, q are placed at the corners of a square of side 'a' as shown in the figure. Find the resultant electric force on a charge Q and the potential energy of this system.

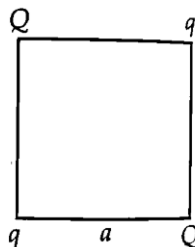

OR

32. Derive an expression for the capacitance of a parallel plate capacitor with air present between the two plates. A capacitor of capacity C_1 is charged to the potential of V_0 . On disconnecting with the battery, it is connected with an uncharged capacitor of capacity C_2 as shown in the adjoining figure. Find the ratio of energies before and after the connection of switch S .

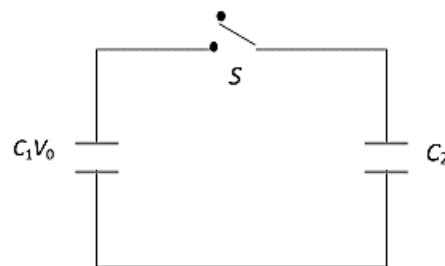

33. (a) (i) State Kirchhoff's rules for an electric network.
 (ii) Using Kirchhoff's rules, obtain the balance condition in terms of the resistances of the four arms of the Wheatstone bridge.
 (b) Plot a graph showing the variation of resistance of a conducting wire as a function of its radius. Keeping the length of the wire and its temperature constant.

OR

33. 4 cells of identical emf ϵ , internal resistance r , are connected in series to a variable resistor. The following graph shows the variation of the terminal voltage of the combination with the current output:

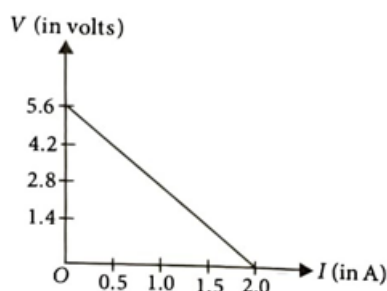

- (i) What is the EMF of each cell used?
 (ii) For what value of the current from the cells, does maximum power dissipation occur in the circuit?
 (iii) Calculate the internal resistance of each cell.